

Gebrauchsanweisung

Notice d'installation

Guida all'installazione

ALTUS RTS

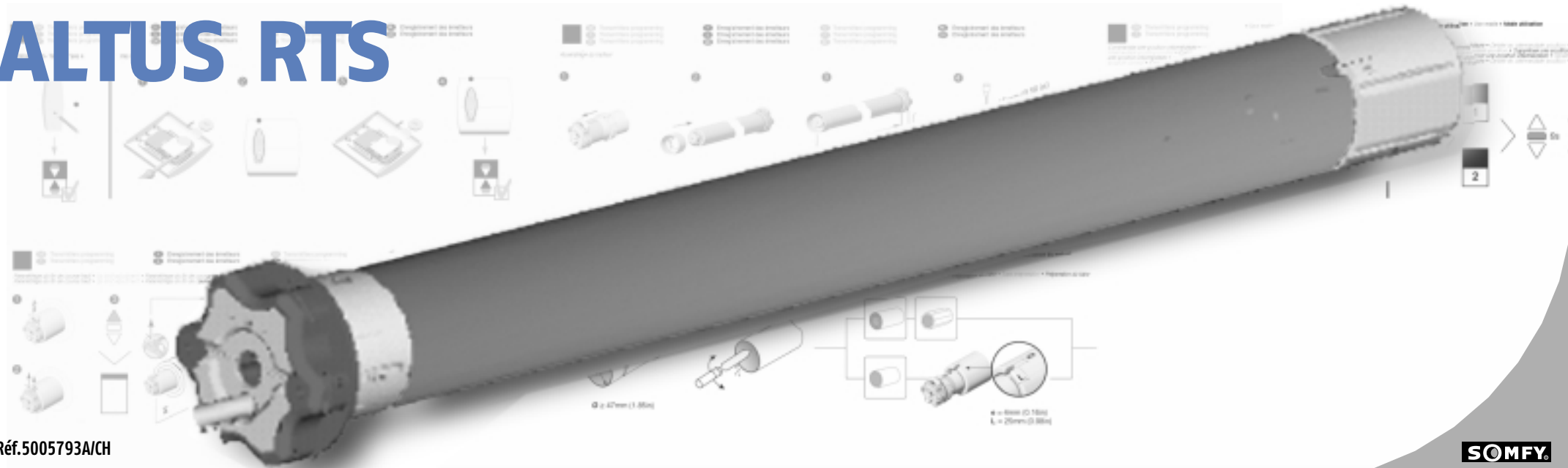

Réf.5005793A/CH

SOMFY.

D

Vor Inbetriebnahme unbedingt die Sicherheitsanweisungen auf beiliegendem Blatt beachten. Bei Nichtbeachten der Gebrauchsanweisung entfällt die Somfy Gewährleistung. Somfy ist nicht haftbar für Änderungen der Normen und Standards nach Erscheinen der Gebrauchsanweisung.

F

Avant la mise en œuvre veuillez lire les instructions de sécurité ci-jointes.
Le non-respect de ces instructions annule la responsabilité de SOMFY et sa garantie. SOMFY ne peut être tenue responsable des changements de normes et standards intervenus après la publication de cette notice.

I

Prima dell'installazione per favore leggere attentamente le istruzioni di sicurezza sul foglio allegato. Il mancato rispetto di queste istruzioni annulla la responsabilità e la garanzia SOMFY. SOMFY non può essere ritenuta responsabile per qualsiasi cambiamento alle norme e agli standards introdotti dopo la pubblicazione di questa guida.

INHALTSVERZEICHNIS • SOMMAIRE • SOMMARIO

1	Antriebsmontage, Einlernen eines Senders	Montage du moteur Enregistrement de la télécommande	Montaggio del motore Programmazione del telecomando
2	Frei wählbare Zwischenposition	Utilisation de la position intermédiaire	Aggiungere o cancellare un comando nella memoria del motore
3	Weitere Sender einlernen oder löschen	Ajout ou suppression d'un émetteur dans la mémoire moteur	Sostituzione di un telecomando perso
4	Ersetzen eines verlorenen Senders	Remplacement d'un émetteur perdu	Vervangen van een verloren bedieningspunt
5	Zurücksetzen in Auslieferungszustand	Effacement complet de la mémoire moteur	Cancellare memoria del motore
6	Ändern der Endlagen	Ré-ajustement des fins de course	Reprogrammazione dei fine corsa
7	Abhilfe bei Störungen	Dépannage	Risoluzione dei problemi

D Kompatible Sender

Telis RTS - Telis RTS silk - Telis RTS patio



F Commandes RTS compatibles

Centralis RTS - Chronis RTS - Inis RT



I Trasmittitori compatibili

Radio Technology Somfy™

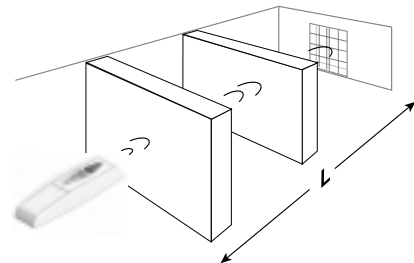

Soliris sensor RTS - Eolis sensor RTS

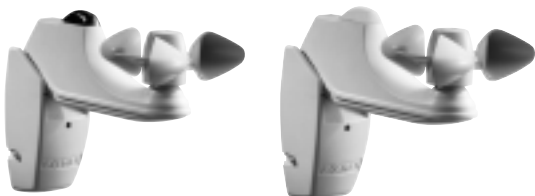

max. 12 Funksender • Capacité mémoire • Capacità di memoria

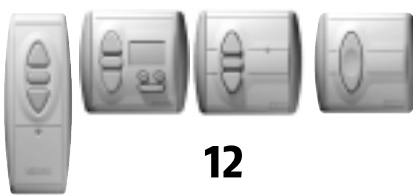

12



3

	L)))
Telis RTS	20 m / 65 ft	433,42 MHz
Centralis RTS		
Chronis RTS		
Inis RT	6 m / 19 ft	
Telis RTS U.S.		

D Verwendete Symbole

F Symboles utilisés dans votre notice

I Simbologia utilizzata nel manuale

Bedienung • *Les actions* • *Gli azionamenti*



- **AUF**
- **Montée**
- **Salita**



- **STOP**
- **Arrêt**
- **Stop**



- **AB**
- **Descente**
- **Discesa**



- **Gleichzeitig drücken**
- **Appui simultané**
- **Pressione simultanea**



→ ▲ , STOP , ▼ , STOP

Zeitangaben • *Temps d'appui* • *Tempo di azione sul pulsante*

2 s-5 s-7 s

- **Drücken für x Sekunden**
- **Maintien minimal**
- **Premere almeno per**

0,5 s

- **Kurz drücken**
- **Appui bref**
- **Impulso breve**



- **Einstellung abgeschlossen**
- **Réglage terminé**
- **Programación correcta**

D Verwendete Symbole

F Symboles utilisés dans votre notice

I Simbologia utilizzata nel manuale

Behang Status • Etat du produit porteur • Stato del prodotto portante



- Untere Position
- Position basse
- Fine corsa basso

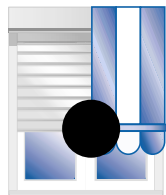

- IP / Zwischenposition
- Position intermédiaire
- Posizioni intermedie

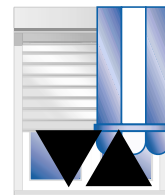

- Kurze Auf / Ab Bewegung
- Bref mouvement (bonne réception)
- Breve movimento di salita e discesa



- Stoppen bei der gewünschten Position
- Arrêt à la position souhaitée
- Arresto alla posizione desiderata

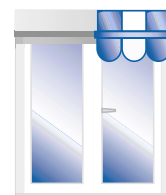

- Obere Position
- Position haute
- Fine corsa alto

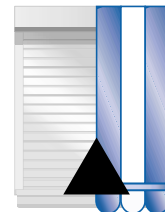

- AUF Bewegung
- Montée
- Salita

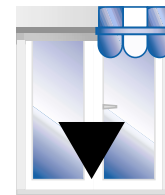

- AB Bewegung
- Descente
- Discesa

D Vorbereitung der Welle

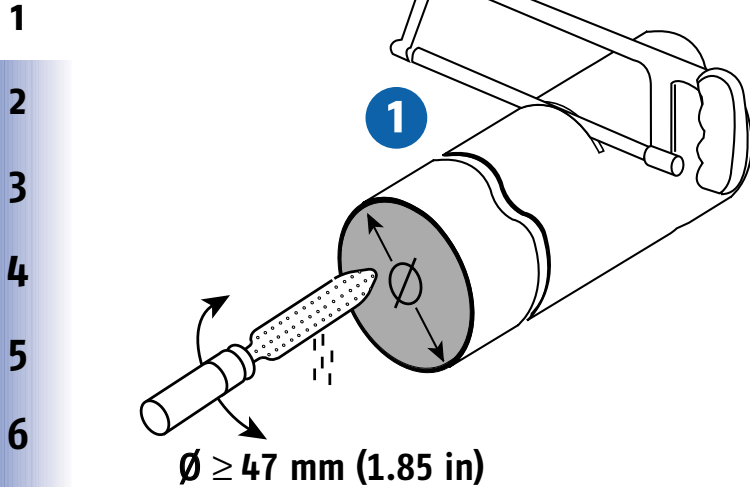

F Préparation du tube

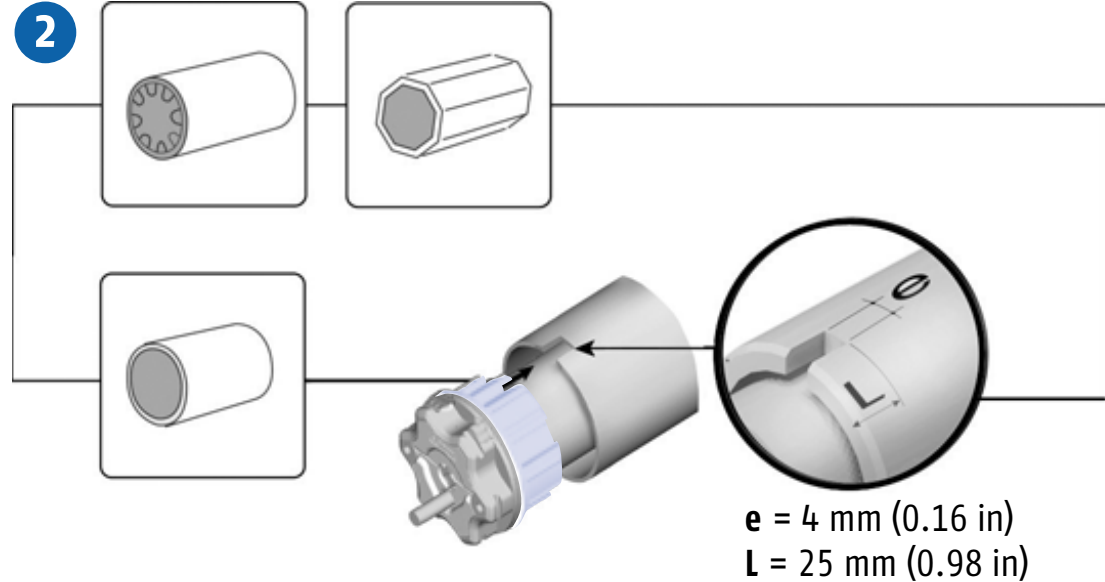

I Preparazione del tubo

D Antriebsmontage

1

2

3

4

5

6

7

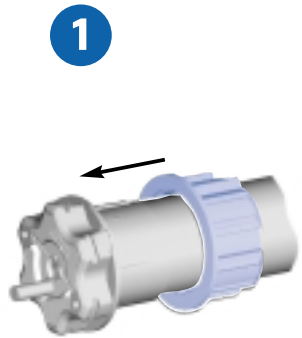

F Assemblage du moteur

2

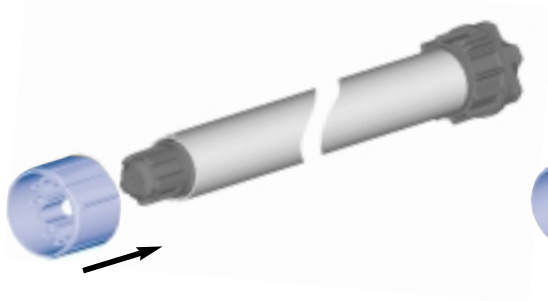

3

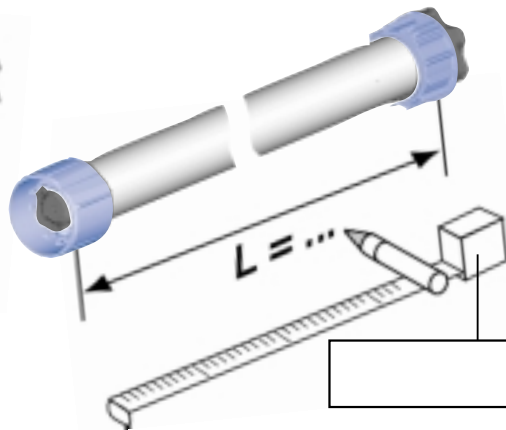

I Montaggio del motore

4

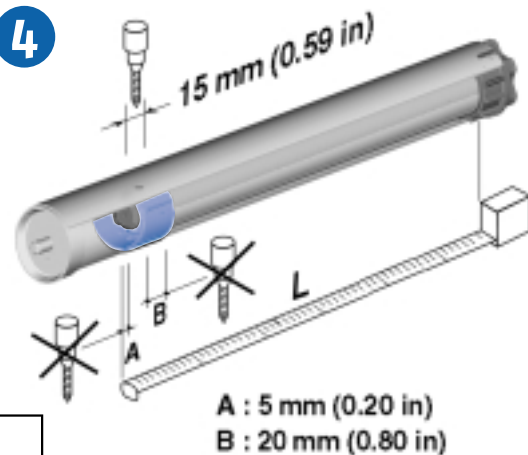

D Montage der Welle in die Lager

F Installer le tube sur ses supports

I Fissaggio del tubo ai suoi supporti

1

2

3

4

5

6

7

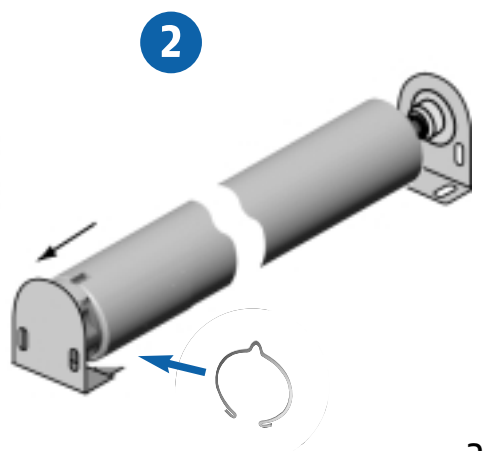
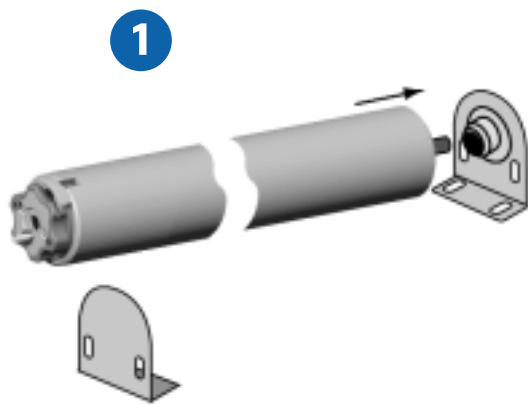
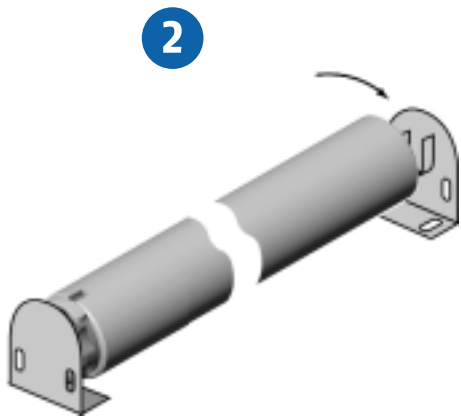
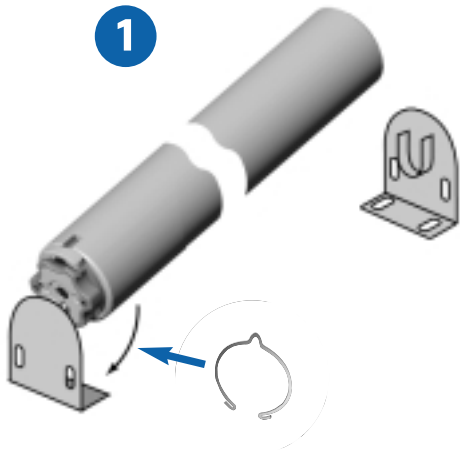

D Stromversorgung und Klemmenbelegung

1

2

3

4

5

6

7

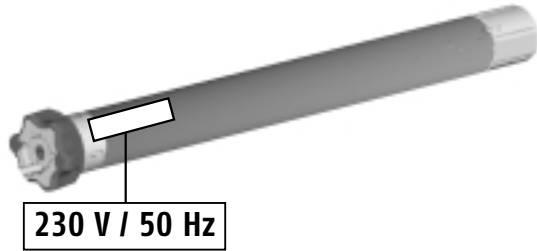

1	· Phase · phase · fase	· Braun · Marron · Marrone
2	· Neutraleiter · neutre · neutro	· Blau · bleu · blu
3	· Erde · terre · terra	· Gelb-Grün · vert-jaune · giallo/verde

F Alimentation et câblage

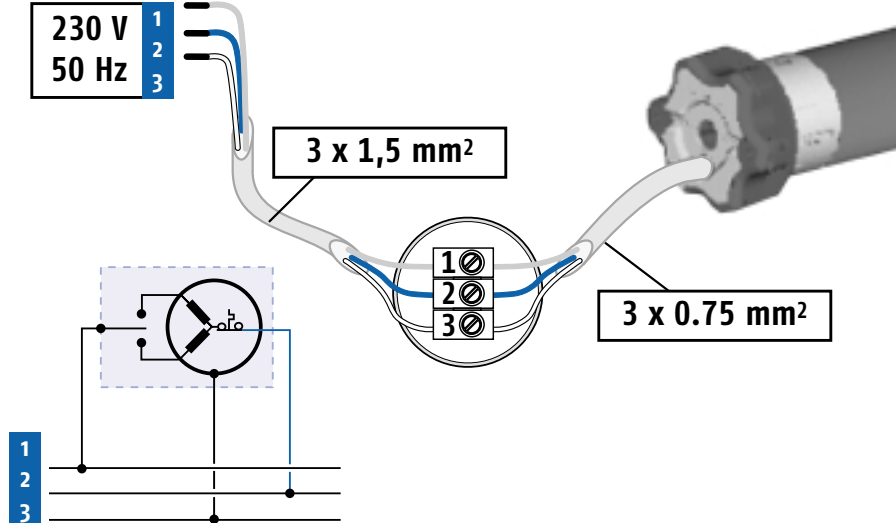

I Alimentazione e cablaggio

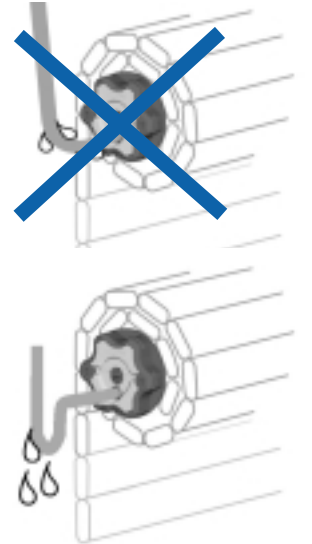

D Einlernen des ersten Senders

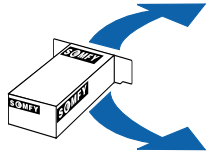
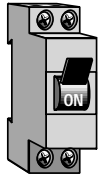
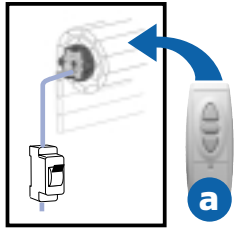

F Enregistrement du premier émetteur

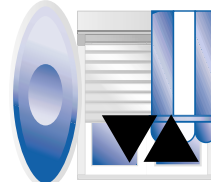
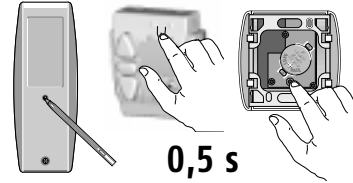

I Programmazione del primo trasmettitore

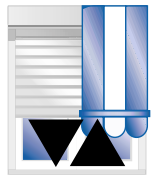
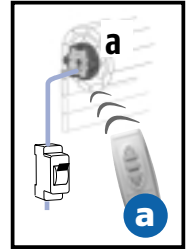

1

2

3

4

5

6

7

1

2

3

4

5

6

7

D Speichern oder ändern Zwischenposition

F Enregistrement ou modification de la position intermédiaire

I Programmazione o modifica della posizione intermedia

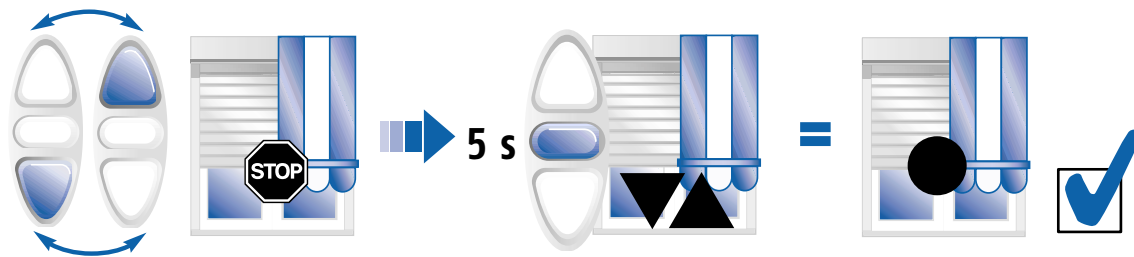

D Bedienergonomie Zwischenposition

F Commander la position intermédiaire

I Comando della posizione intermedia

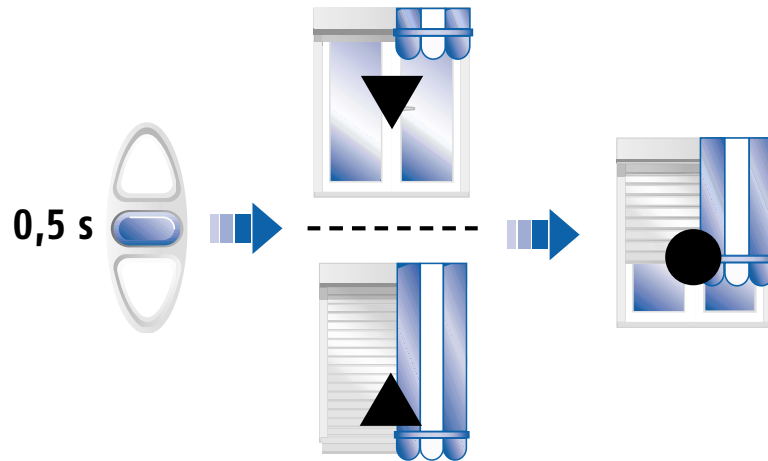

D Löschen der Zwischenposition

F Suppression de la position intermédiaire

I Cancellazione di una posizione intermedia

1

2

3

4

5

6

7

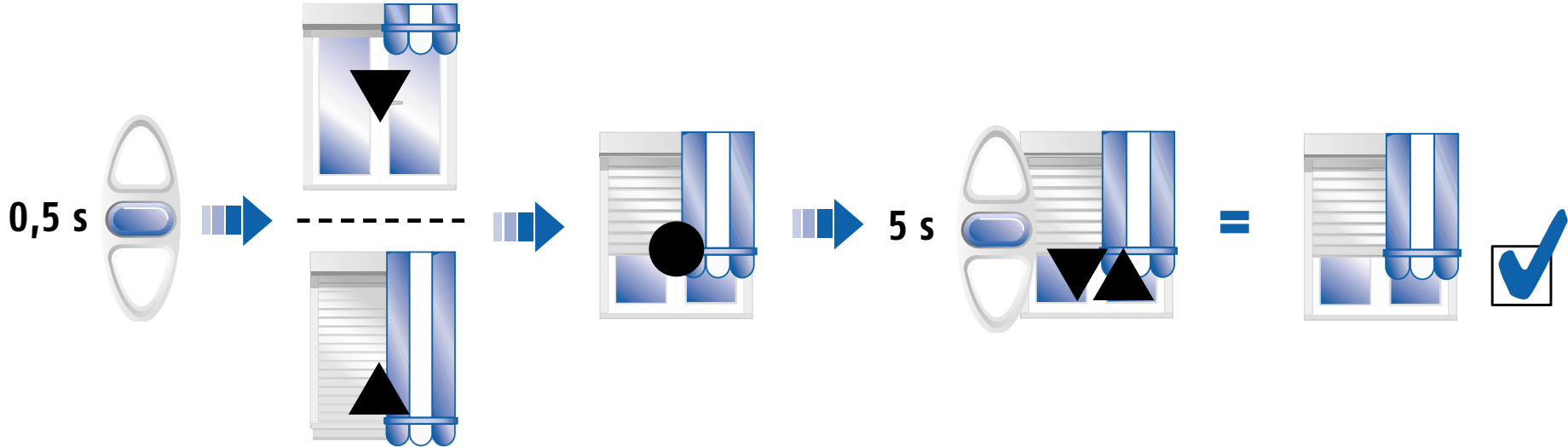

D Weitere Sender einlernen

F Ajout d'un émetteur dans la mémoire moteur

I Aggiungere o cancellare un comando nella memoria del motore

1

2

3

4

5

6

7

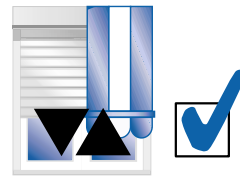
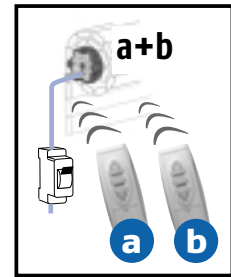
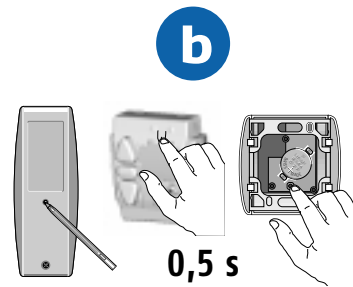
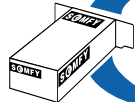
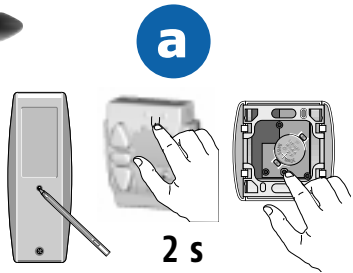
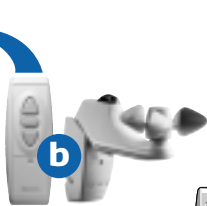
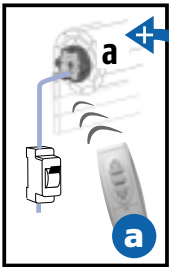

D Einen Sender löschen

F Suppression d'un émetteur dans la mémoire moteur

I Cancellare un comando nella memoria del motore

1
2
3
4
5
6
7

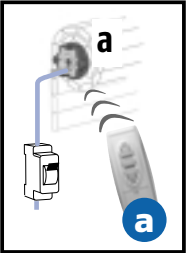
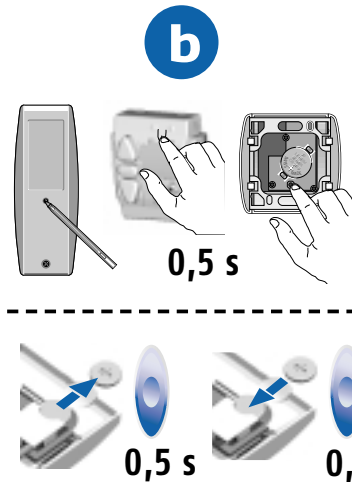
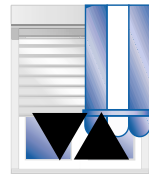
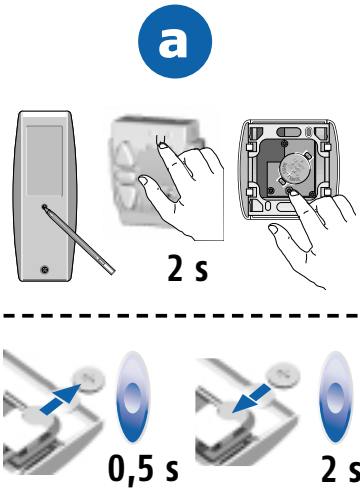
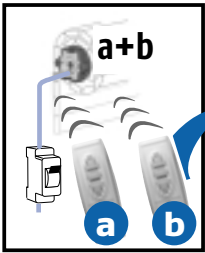

D Ersetzen eines verlorenen Senders

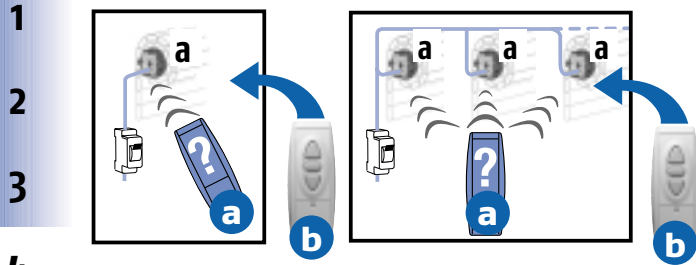

4

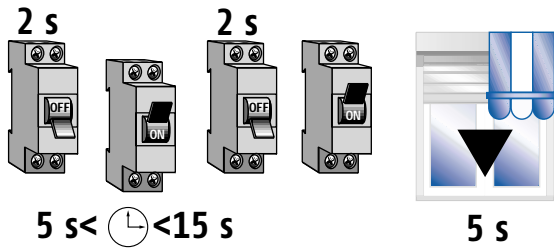

5

6

7

F Remplacement d'un émetteur perdu

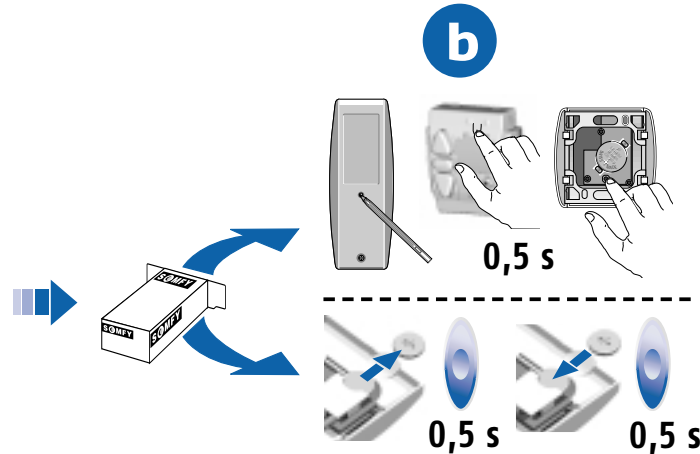

I Sostituzione di un telecomando perso

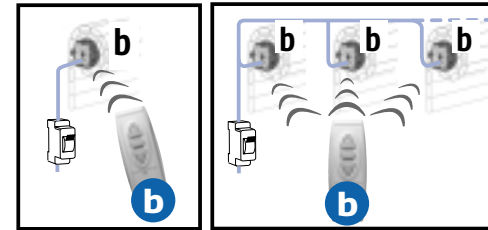

D Ersetzen eines verlorenen Senders

1
2
3

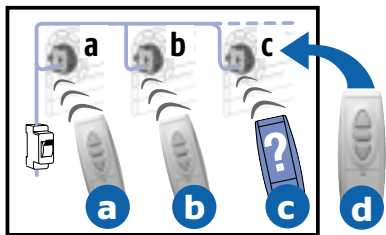

4

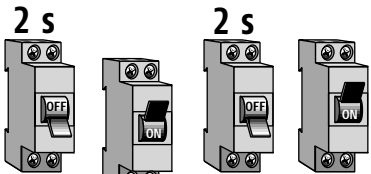

5

6

7

5 s <  < 15 s

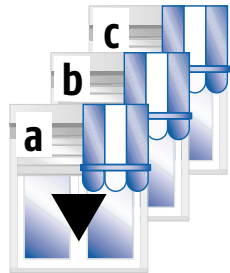

5 s

F Remplacement d'un émetteur perdu

a

0,5 s



b

0,5 s

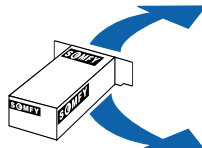

d

0,5 s

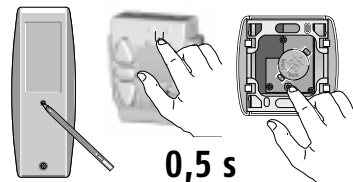

0,5 s



0,5 s

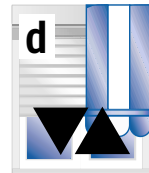

I Sostituzione di un telecomando perso

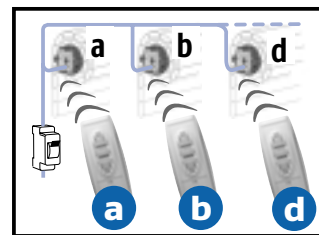

13

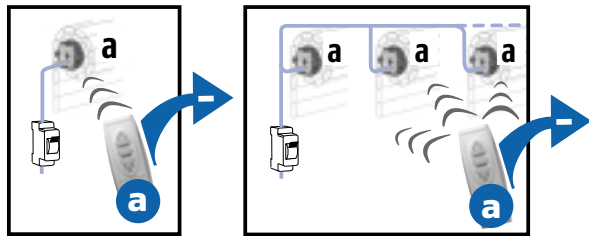
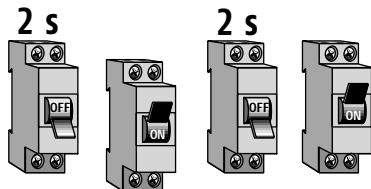
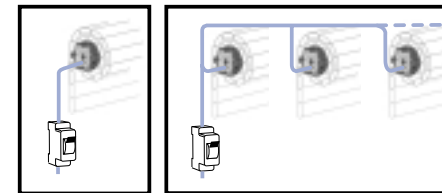
D**Zurücksetzen aller Motoren
in Auslieferungszustand****F****Effacement complet
de la mémoire moteur****I****Cancellare memoria del motore**

5 s < 15 s

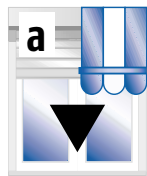

5 s

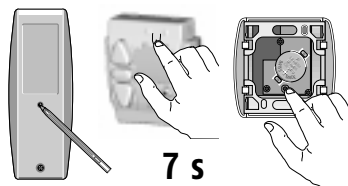

7 s

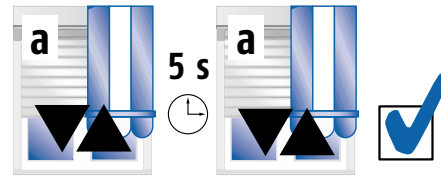

5 s

D Zurücksetzen eines Motors
in Auslieferungszustand

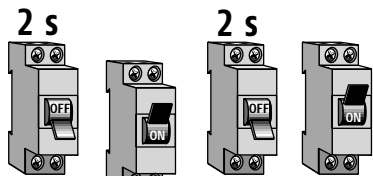
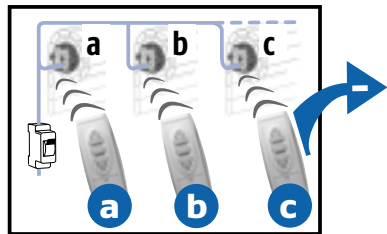

5 s < ⌚ < 15 s

F Effacement complet
de la mémoire moteur

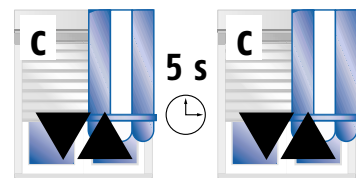
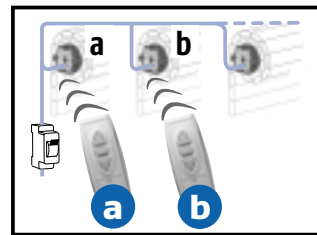
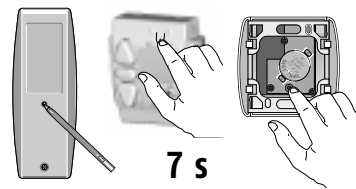
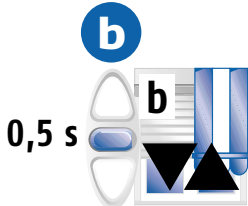
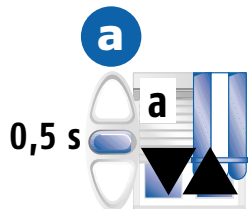
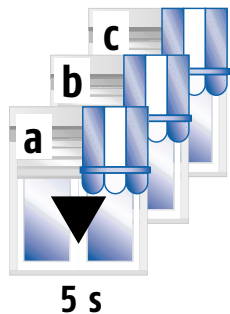

15

I Cancellare memoria del motore

D Ändern der Endlagen

F Réajustement des fins de course

I Riprogrammazione dei fine corsa

1

D Ändern der oberen Endlage

2

F Réglage limite haute

3

I Regolazione del fine corsa alto

4

5

D Ändern der unteren Endlage

6

F Réglage limite basse

7

I Regolazione del fine corsa basso

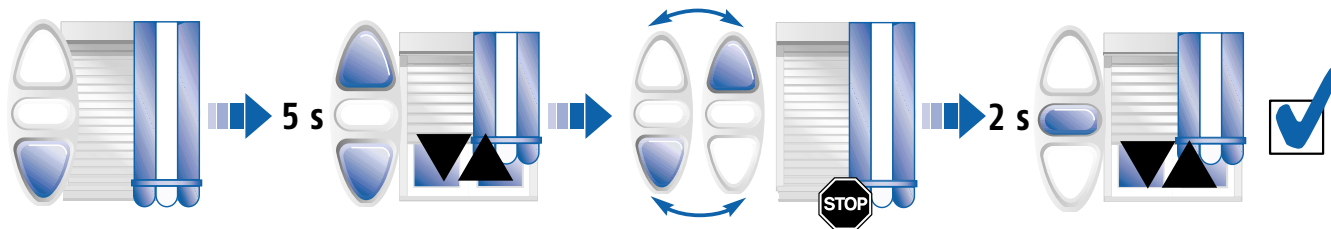
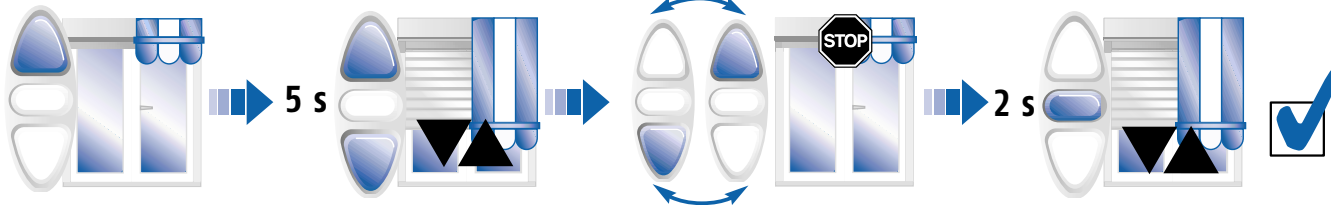

D Abhilfe bei Störungen:

1 Der Motor reagiert nicht :

Überprüfen Sie:

- den elektrischen Anschluß
- 2** • ob der Thermoschutz ausgelöst hat (Abkühlen lassen)
- 3** • ob das richtige Anschlußkabel verwendet wurde (RTS Kabel)
- die Batterie des Funksenders
- 4** • ob der Sender eingelernt wurde
- ob Funkstörungen auftreten

5

6 Der Antrieb stoppt zu früh :

Überprüfen Sie:

- 7** • die Einstellung der Endlagen
- ob der Adapter fest mit der Welle verbunden ist

D Dépannage

Le moteur ne fonctionne pas :

Vérifier :

- le câblage du moteur
- le contact thermique (attendre le refroidissement du moteur)
- la conformité du câble utilisé (3 conducteurs)
- la pile de la télécommande
- la compatibilité des télécommandes
- la bonne mémorisation de la télécommande par le moteur
- l'absence d'interférences radio

L'appareillage s'arrête trop tôt :

Vérifier :

- que la couronne d'entraînement est bien solidarisée au tube (voir § 1)
- que les fins de course du moteur soient bien réglées (voir § 1)

D Risoluzione dei problemi

L'operatore non funziona correttamente :

Verificare :

- Il cablaggio del motore
- la termica (aspettare che il motore si raffreddi)
- la conformità del cavo utilizzato (3 fili)
- la batteria del telecomando
- la compatibilità del telecomando
- la corretta memorizzazione del telecomando nel motore
- l'assenza di interferenze radio

L'apparecchio si ferma prima :

Verificare :

- la corona di trascinamento sia ben adattata al tubo (vedere paragrafo 1)
- i fine corsa del motore siano ben regolati (vedere paragrafo 1)



A series of horizontal dotted lines spanning the width of the page, providing a guide for handwriting practice.



A series of horizontal dotted lines spanning the width of the page, providing a guide for handwriting practice. The lines are arranged in three columns and extend across the entire page.



A large writing area consisting of three vertical columns of horizontal dotted lines, intended for student responses.

CE Hiermit erklärt SOMFY, dass dieses Produkt den wesentlichen Anforderungen und anderen relevanten Vorschriften der Direktive 1999/5/EC entspricht. Die Konformitätserklärung kann abgerufen werden unter der Internet-Adresse www.somfy.com, Klausel verwendbar in EU, (CH)

CE Nous SOMFY, déclarons que ce produit est conforme aux exigences essentielles et autres dispositions pertinentes de la directive 1999/5/EC. Une déclaration de conformité est mise à disposition à l'adresse Internet www.somfy.com rubrique CE. Utilisable en UE, (CH)

CE Noi, SOMFY, dichiariamo che questo prodotto è conforme alle esigenze essenziali, così come alle altre disposizioni pertinenti, previste dalla direttiva 1999/5/EC. Un'apposita dichiarazione di conformità è stata messa a disposizione all'indirizzo internet www.somfy.com Rubrica CE. Utilizzabile in EU, (CH)



www.somfy.com

Australia : SOMFY PTY LTD
www.somfy.com.au

Austria : SOMFY GesmbH
www.somfy.at

Belgium : NV SOMFY SA
www.somfy.be

Brasil : SOMFY BRASIL STDA
www.somfy.com

Canada : SOMFY ULC
www.somfy.com

Cyprus : SOMFY MIDDLE EAST
www.somfy.com

Czech Republic : SOMFY Spol s.r.o.
www.somfy.com

Denmark : SOMFY AB DENMARK
www.somfy.dk

Finland : SOMFY AB FINLAND
www.somfy.se

France : SOMFY FRANCE
www.somfy.fr

Germany : SOMFY GmbH
www.somfy.de

Greece : SOMFY HELLAS
www.somfy.com

Hong Kong : SOMFY Co. Ltd
www.somfy.com

Hungary : SOMFY Kft
www.somfy.com

India : SOMFY INDIA PVT Ltd
www.somfy.com

Italy : SOMFY ITALIA S.R.L
www.somfy.it

Japan : SOMFY KK
www.somfy.co.jp

Lebanon : cf. Cyprus - somfy middle east
www.somfy.com

Mexico : SOMFY MEXICO SA de CV
www.somfy.com.mx

Morocco : SOMFY MAROC
www.somfy.com

Netherlands : SOMFY BV
www.somfy.nl

Norway : SOMFY NORWAY
www.somfy.se

Poland : SOMFY SP Z.O.O
www.somfy.pl

Portugal : cf. Spain - SOMFY ESPANA SA
www.somfy.com

Russia : cf. Germany - SOMFY GmbH
www.somfy.de

Singapore : SOMFY PTE LTD
www.somfy.com.sg

Slovaquia : cf. Czech Republic - SOMFY Spol s.r.o.
www.somfy.com

South Korea : SOMFY JOO
www.somfy.co.kr
Spain : SOMFY ESPANA SA
www.somfy.com

Sweden : SOMFY AB
www.somfy.se

Switzerland : SOMFY A.G.
www.somfy.ch

Taiwan : SOMFY TAIWAN
www.somfy.com

United Kingdom : Somfy LTD
www.somfy.co.uk

United States :
SOMFY SYSTEMS Inc
www.somfysystems.com